



DX700LC TECHNICAL DATA





GENERAL SPECIFICATIONS

ITEMS		UNIT	STANDARD
ENGINE	MODEL		ISUZU AH-6WG1XYSC-01
	NUMBER OF CYLINDERS		6
	RATED FLYWHEEL POWER (GROSS) (hp PER SAE J1995)	hp / rpm	463 / 1,800
		kW / rpm	345 / 1,800
	RATED FLYWHEEL POWER (NET) (hp PER SAE J1349)	hp / rpm	401 / 1800
		kW / rpm	299 / 1800
	MAXIMUM TORQUE (GROSS) (SAE J1995)	ft. lb. / rpm	1,460 / 1,500
		Nm / rpm	1,980 / 1,500
	PISTON DISPLACEMENT	in ³	957
		cc	15,681
	BORE AND STROKE	in. x in.	5.8 x 6.1
mm x mm		147 x 154	
STARTER	V / kW	24 V, 7.0 kW	
BATTERIES	V / AH	2 x 12 V x 150 AH	
AIR CLEANER		Double element with Pre-Cleaner.	
MAIN PUMPS – 2 VARIABLE DISPLACEMENT AXIAL PISTON PUMPS (MAX. FLOW)		US gpm	2 x 115
		L / min.	2 x 436
PILOT PUMP (GEAR DESIGN)	MAX. FLOW	US gpm	7.1
		L / min.	27
	RELIEF PRESSURE	psi	566
		bar	39
MAX. SYSTEM PRESSURE	BOOM/ARM/BUCKET (NORMAL MODE)	psi	4,551
		bar	314
	BOOM/ARM/BUCKET (POWER MODE)	psi	4,978
		bar	343
	TRAVEL	psi	4,551
		bar	314
SWING	psi	4,253	
	bar	293	
UNDERCARRIAGE	UPPER ROLLERS		3 each track (STD. Shoes)
	LOWER ROLLERS		8 each track
	NUMBER OF SHOES (LINKS PER SIDE)		48 each track (Triple Grouser)
	TOTAL LENGTH OF TRACK	ft. in.	15'7"
mm		4,750	
ENVIRONMENT	SOUND LEVEL (2000/14/EC)	dB(A)	108
	CABIN SOUND LEVEL (ISO 6396)	dB(A)	76
SWING MECHANISM	SWING SPEED	rpm	0 - 7.1
DRIVE SYSTEM	TRAVEL SPEED (FAST/SLOW)	mph	2.9 / 1.7
		km / h.	4.6 / 2.8
	DRAWBAR PULL	lb.	107,806
		kg	48,900
	MAX. GRADE	%	70
°		35	

DX700LC

ITEMS		UNIT	STANDARD
REFILL CAPACITIES	FUEL TANK	US gal	237.8
		L	900
	COOLING SYSTEM (RADIATOR CAPACITY)	qt.	73
		L	69
	ENGINE OIL	qt.	55
		L	52
	SWING DRIVE (EACH)	qt.	6.3
		L	6
	FINAL DRIVE (EACH SIDE)	qt.	21
		L	20
	HYDRAULIC SYSTEM (INCLUDES HYDRAULIC TANK)	US gal	209
		L	790
	HYDRAULIC TANK	US gal	92.5
		L	350

WEIGHT

BOOM	25'3" (7.7 m)	
ARM	11'8" (3.55 m)	
BUCKET	SAE 4.32 yd³ (3.3 m³)	
SHOE WIDTH (TRIPLE GROUSER)	OPERATING WEIGHT	GROUND PRESSURE
25.6" (650 mm)	154,544 lb. (70,100 kg)	14.5 psi (1.00 bar)
29.5" (750 mm)	156,749 lb. (71,100 kg)	12.9 psi (0.89 bar)
35.4" (900 mm) STD	158,953 lb. (72,100 kg)	11.0 psi (0.76 bar)

HYDRAULIC CYLINDERS

The piston rods and cylinder bodies are made of high-strength steel. A shock absorbing mechanism is fitted in all cylinders to ensure shock-free operation and extend piston life.

CYLINDERS	QUANTITY	BORE x ROD DIAMETER x STROKE
BOOM	2	7.5" x 4.9" x 5'11" (190 x 125 x 1,795 mm)
ARM	1	8.5" x 5.9" x 6'8" (215 x 150 x 2,030 mm)
BUCKET	1	7.5" x 5.1" x 4'10" (190 x 130 x 1,465 mm)



BUCKET

CAPACITY		WIDTH		WEIGHT	RECOMMENDATIONS				
					25'3" STD (7,700 mm) BOOM			21'10" (6,650 mm) BOOM	
SAE (HEAPED)	CECE (HEAPED)	WITHOUT SIDE CUTTERS	WITH SIDE CUTTERS		11'8" STD (3,550 mm) ARM	9'6" (2,900 mm) ARM	13'9" (4,200 mm) ARM	9'6" (2,900 mm) ARM	8'6" (2,600 mm) ARM
3.27 yd ³ (2.5 m ³)	2.92 yd ³ (2.23 m ³)	61.6" (1,565 mm)	-	5,556 lb (2,520 kg)	A	A	A	A	A
3.92 yd ³ (3.0 m ³)	3.53 yd ³ (2.7 m ³)	71.1" (1,805 mm)	-	6,206 lb (2,815 kg)	A	A	B	A	A
4.32 yd ³ (3.3 m ³) STD	3.79 yd ³ (2.9 m ³) STD	76.5" (1,944 mm)	-	6,658 lb (3,020 kg)	B	B	C	A	A
5.10 yd ³ (3.9 m ³)	4.53 yd ³ (3.46 m ³)	78.7" (1,999 mm)	-	7,011 lb (3,180 kg)	C	C	D	A	A
5.89 yd ³ (4.5 m ³)	5.19 yd ³ (3.97 m ³)	88.5" (2,249 mm)	-	7,716 lb (3,500 kg)	X	D	X	B	B
3.92 yd ³ (3.0 m ³) HD	3.66 yd ³ (2.8 m ³) HD	60.9" (1,548 mm)	-	7,297 lb (3,310 kg)	B	A	C	A	A
4.32 yd ³ (3.3 m ³) HD	3.92 yd ³ (3.0 m ³) HD	66.0" (1,676 mm)	-	7,606 lb (3,450 kg)	C	B	D	A	A
5.10 yd ³ (3.9 m ³) HD	4.58 yd ³ (3.5 m ³) HD	75.9" (1,928 mm)	-	8,223 lb (3,730 kg)	D	C	X	B	A
5.89 yd ³ (4.5 m ³) HD	5.36 yd ³ (4.1 m ³) HD	85.8" (2,180 mm)	-	9,017 lb (4,090 kg)	X	D	X	C	B

A. Suitable for materials with density of 2,100 kg•m³ (3,500 lb. / yd³) or less

B. Suitable for materials with density of 1,800 kg•m³ (3,000 lb. / yd³) or less

C. Suitable for materials with density of 1,500 kg•m³ (2,500 lb. / yd³) or less

D. Suitable for materials with density of 1,200 kg•m³ (2,000 lb. / yd³) or less

X. Not recommended

DIGGING FORCE (ISO)

BUCKET (PCSA)	3.27 yd ³ (2.5 m ³)	3.92 yd ³ (3.0 m ³)	4.32 yd ³ (3.3 m ³) STD	5.10 yd ³ (3.9 m ³)	5.89 yd ³ (4.5 m ³)	3.92 yd ³ (3.0 m ³) HD	4.32 yd ³ (3.3 m ³) HD	5.10 yd ³ (3.9 m ³) HD	5.89 yd ³ (4.5 m ³) HD
DIGGING FORCE	78,485 lbf.	78,485 lbf.	78,485 lbf.	88,626 lbf.	88,626 lbf.	76,721 lbf.	76,721 lbf.	85,098 lbf.	85,098 lbf.
	35,600 kgf.	35,600 kgf.	35,600 kgf.	40,200 kgf.	40,200 kgf.	34,800 kgf.	34,800 kgf.	38,600 kgf.	38,600 kgf.
	349.1 kN	349.1 kN	349.1 kN	394.2 kN	394.2 kN	341.3 kN	341.3 kN	378.5 kN	378.5 kN

ARM	11'8" STD (3,550 mm)	9'6" (2,900 mm)	8'6" (2,600 mm)	13'9" (4,200 mm)
DIGGING FORCE	64,595 lbf.	73,855 lbf.	78,044 lbf.	57,761 lbf.
	29,300 kgf.	33,500 kgf.	35,400 kgf.	26,200 kgf.
	287 kN	329 kN	347 kN	257 kN

DX700LC

DIMENSIONS

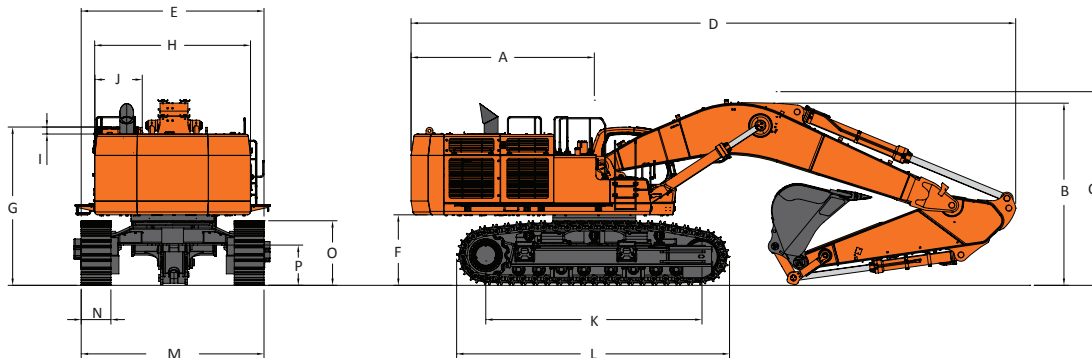

BOOM TYPE		25'3" STD (7,700 mm)			21'10" (6,650 mm)	
ARM TYPE		11'8" STD (3,550 mm)	9'6" (2,900 mm)	13'9" (4,200 mm)	9'6" (2,900 mm)	8'6" (2,600 mm)
BUCKET TYPE (SAE)		4.32 yd ³ (3.3 m ³)	4.32 yd ³ (3.3 m ³)	3.92 yd ³ (3.0 m ³)	5.10 yd ³ (3.9 m ³)	5.89 yd ³ (4.5 m ³)
TAIL SWING RADIUS	A	13'5" (4,090 mm)	←	←	←	←
SHIPPING HEIGHT (BOOM)	B	13'4" (4,063 mm)	14'6" (4,418 mm)	16'5" (5,015 mm)	16'2" (4,920 mm)	15'7" (4,750 mm)
SHIPPING HEIGHT (HOSE)	C	13'10" (4,220 mm)	14'10" (4,520 mm)	16'10" (5,130 mm)	16'5" (5,000 mm)	16'0" (4,870 mm)
SHIPPING LENGTH	D	43'6" (13,250 mm)	44'0" (13,400 mm)	42'11" (13,085 mm)	40'6" (12,335 mm)	←
SHIPPING WIDTH	E	12'0" (3,650 mm)	←	←	←	←
C / WEIGHT CLEARANCE	F	5'0" (1,525 mm)	←	←	←	←
HEIGHT OVER CABIN	G	11'6" (3,515 mm)	←	←	←	←
HOUSE WIDTH	H	11'2" (3,410 mm)	←	←	←	←
CABIN HEIGHT (ABOVE HOUSE)	I	8" (208 mm)	←	←	←	←
CABIN WIDTH	J	3'4" (1,010 mm)	←	←	←	←
TUMBLER DISTANCE	K	15'6" (4,730 mm)	←	←	←	←
TRACK LENGTH	L	19'7" (5,975 mm)	←	←	←	←
UNDERCARRIAGE WIDTH	M	12'0" (3,650 mm) / 13'11" (4,650 mm)	←	←	←	←
SHOE WIDTH	N	35.4" (900 mm)	←	←	←	←
TRACK HEIGHT	O	4'8" (1,413 mm)	←	←	←	←
CAR BODY CLEARANCE	P	2'10" (870 mm)	←	←	←	←

WORKING RANGE

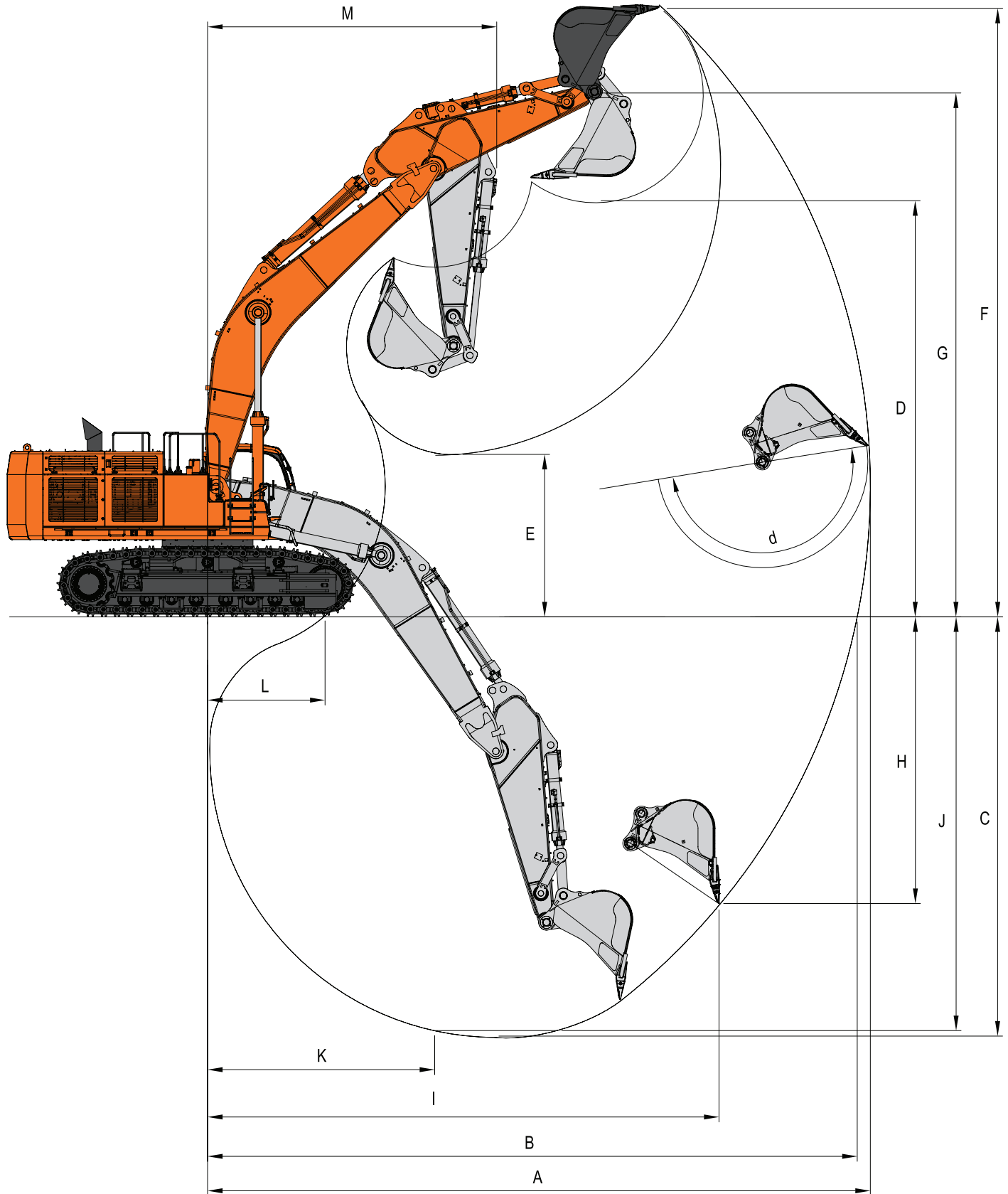

DX700LC

BOOM TYPE		25'3" STD (7,700 mm)			21'10" (6,650 mm)	
ARM TYPE		11'8" STD (3,550 mm)	9'6" (2,900 mm)	13'9" (4,200 mm)	9'6" (2,900 mm)	8'6" (2,600 mm)
BUCKET TYPE (SAE)		4.32 yd ³ (3.3 m ³)	4.32 yd ³ (3.3 m ³)	3.92 yd ³ (3.0 m ³)	5.10 yd ³ (3.9 m ³)	5.89 yd ³ (4.5 m ³)
MAX. DIGGING REACH	A	43'6" (13,250 mm)	41'9" (12,720 mm)	45'6" (13,865 mm)	38'1" (11,605 mm)	37'3" (11,345 mm)
MAX. DIGGING REACH (GROUND)	B	42'7" (12,990 mm)	40'10" (12,450 mm)	44'8" (13,610 mm)	37'1" (11,305 mm)	36'3" (11,040 mm)
MAX. DIGGING DEPTH	C	27'7" (8,410 mm)	25'4" (7,730 mm)	29'8" (9,030 mm)	23'3" (7,075 mm)	22'3" (6,780 mm)
MAX. LOADING HEIGHT	D	27'4" (8,320 mm)	27'0" (8,220 mm)	28'5" (8,660 mm)	23'0" (7,020 mm)	22'9" (6,940 mm)
MIN. LOADING HEIGHT	E	10'8" (3,248 mm)	13'0" (3,950 mm)	8'8" (2,630 mm)	10'1" (3,080 mm)	11'1" (3,380 mm)
MAX. DIGGING HEIGHT	F	39'11" (12,165 mm)	39'6" (12,040 mm)	41'1" (12,520 mm)	35'3" (10,740 mm)	35'0" (10,680 mm)
MAX. BUCKET (PIN HEIGHT)	G	34'4" (10,470 mm)	34'1" (10,380 mm)	35'5" (10,795 mm)	30'3" (9,210 mm)	30'0" (9,135 mm)
MAX. VERTICAL WALL DEPTH	H	18'10" (5,730 mm)	13'4" (4,060 mm)	21'4" (6,515 mm)	11'4" (3,450 mm)	10'10" (3,305 mm)
MAX. RADIUS (VERTICAL)	I	33'7" (10,230 mm)	35'5" (10,790 mm)	34'0" (10,360 mm)	32'4" (9,860 mm)	31'8" (9,655 mm)
MAX. DEPTH (8' LINE)	J	27'2" (8,270 mm)	24'9" (7,550 mm)	29'3" (8,910 mm)	22'9" (6,925 mm)	21'9" (6,620 mm)
MIN. RADIUS (8' LINE)	K	14'11" (4,540 mm)	14'10" (4,530 mm)	34'0" (10,360 mm)	12'6" (3,800 mm)	12'5" (3,785 mm)
MIN. DIGGING REACH	L	7'9" (2,350 mm)	10'0" (3,060 mm)	7" (170 mm)	6'0" (1,835 mm)	6'9" (2,050 mm)
MIN. SWING RADIUS	M	19'0" (5,780 mm)	19'0" (5,790 mm)	19'1" (5,810 mm)	17'2" (5,230 mm)	17'1" (5,195 mm)
BUCKET ANGLE	d	179.4°	177.8°	179.4°	167.4°	166.4°



STANDARD EQUIPMENT

ENGINE

ISUZU AH-6WG1XYSC-01; Turbo Charged and Aftercooled
Electronically Controlled Common Rail Direct Injected
956.9 cu. in., 6 Cylinder
401 (299 kW) SAE Net Flywheel Horsepower @ 1,800 rpm
Auto Idle System
Equipped with the Fuel Pre-Filter with Water Separator
& Built In Priming Pump
Radiator Reserve Tank
Large Capacity Double Element Air Cleaner with Pre-Cleaner
Electronic Engine Speed Control
Engine Overheat and Low Oil Pressure Prevention System

HYDRAULIC SYSTEM

Pilot Operated Control Valves, (9) Spools
Main Pump:
– Tandem, Axial Piston, Pressure Setting 4,970 psi (343 bar)
Pilot Circuit:
– Gear Type Pump
Swing Motor:
– Axial Piston Type
– Swing Speed Control up to 7.1 rpm
– Spring Set, Hydraulic-Released Brakes
Travel Motor:
– Axial Piston Type, Automatic 2-Speed Control
Travel Speed (High/Low):
– 2.9 mph / 1.8 mph
In-Shoe Design, Oil Disc Parking Brake
Cross Sensing Pump Control for Fuel Saving
Three Power Modes (PWR/STD/ECO)
Two Lifting Modes (Digging/Lifting)
Button Control of Flow in Auxiliary Equipment Circuits
Computer-Aided Pump Power Control
e-EPOS (Electronic Power Optimizing System) Controller
One Way Aux to the Base of the Boom

CAB

Steel, All Weather Sound Suppressed Type
Fully Automatically Controlled Air Conditioner with Heat
Multi-Function Color LCD Monitor Panel
Cigarette Lighter with Ashtray
Door Locks
Front Windshield Wiper with Washer
Radio:
– AM/FM Stereo with Cassette
– Remote Radio On/Off Switch, Control Volume, Channel Selection
Switches:
– Auxiliary Mode Switch
– Engine Emergency Stop Switch
– Work Light Switch
– Travel Speed Selector Switch
– Breaker, Power-Up, Shear Switch
Glass Antenna
Safety Glass, Tinted
Safety Lock Lever
Seat:
– Suspension with Seat Belt (2 Wide)
– Reclining, Height Adjustable
– Adjustable Arm Rests
– Sliding Control Console
– Weight Adjustment Knob
Skylight
Pull Up Type Front Window
Removable Lower Front Window
Sliding Side Windows
Front Window Air Defroster
Travel Pedals with Hand Levers
Emergency Breakout Tool
Lunch Box with Hot & Cool Air
12V Power Socket
Joystick Lever with 3 Switches
Cup Holder
Room Light
Serial Communication Port for Laptop PC Interface (DMS, E-Doctor)
Viscous Cab Mounts

ELECTRICAL

Alternator:

- 80 Amp.

Batteries:

- (2) 12 Volt, 150 Amp. Hrs. 950 CCA ea

Starter:

- 24 Volt, 7 kW

Lights:

- Halogen Working Light (1) Machine, (2) Boom

Electric Horn

Hour Meter

Alarm Buzzer for:

- Engine Oil Pressure
- Coolant Temperature

Electronic Monitor for:

- Engine Coolant Temperature Gauge
- Fuel Gauge
- Hydraulic Oil Temperature Gauge

Multi-Function Display for:

- Engine rpm
- Battery Voltage
- Front and Rear Hydraulic Pump Pressure
- Hydraulic Oil Overheating Warning
- Fuel Shortage Warning
- Air Cleaner Clogging Warning
- Pilot Filter Clogging Warning
- Return Filter Clogging Warning
- Digital Clock
- Engine Check Warning Light
- Engine Oil Pressure Warning Light
- Charge Warning Light
- Preheat Indicator Light
- Coolant Temperature Warning Light
- Work Light Indicator Light

Operation Modes for:

- Power Mode Select Button
- Economic Mode Select Button
- Flow Rate Control
- Auto Idle Select Button
- 4 Display Selection Buttons

UNDERCARRIAGE

Track Guards and Chains with Adjusters

Track Rollers:

- (3) Upper, (8) Lower Each Side

Triple Grouser Shoes, 48 Each Side; 900 mm Width

OTHER STANDARD EQUIPMENT

Joystick Pattern Change Valve

Counterweight:

- 24,912 lb. (11,300 kg.)

Sealed Pins, Boom, Arm and Bucket Linkages

Swing Mechanism, Internal Gear and Pinion

Integrated Track Spring and Idler

Centralized Lube Points

Large Handrail

Punched Metal Anti-Slip Plates

Ultra-Hard Wear-Resistant Disc at the Bucket Pivot

Engine Restart Prevention System

Self-Diagnostic System

Manuals:

- Parts and Operator's

GPS with 1 Year Subscription

OPTIONAL EQUIPMENT

HYDRAULIC KITS – FACTORY INSTALLED

Single Acting Breaker Kit

Double Acting Thumb Kit

ADDITIONAL OPTIONS – FACTORY INSTALLED

Automatic Lubrication System

CD Player

Full Length Track Guard

Rotating Beacon (Mounted on Cabin)

Swing Alarm

Work Lights (2 Front Mounted on Cabin)

Work Lights (4 Front 2 Rear Mounted on Cabin)



LIFTING CAPACITY

Boom: 21'10" (6,650 mm)

Arm: 8'6" (2,600 mm)

Bucket: None

Shoe: 35.4" (900 mm)

Counterweight: 12.5 ton (11.3 metric ton)

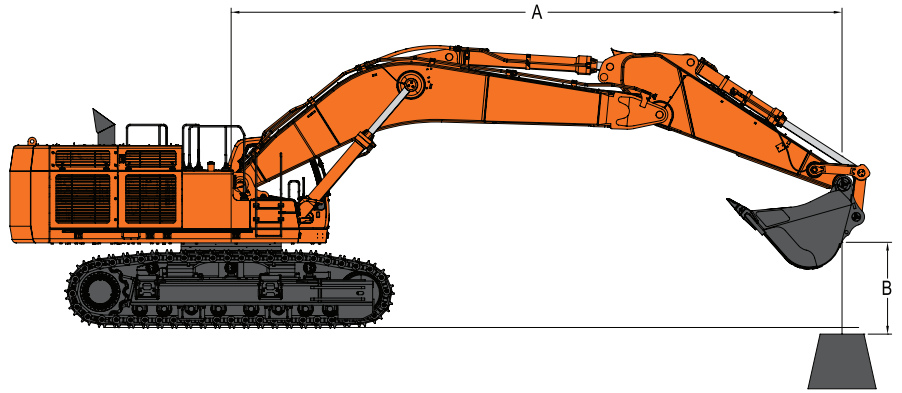

Feet - T70 + 6.65B + 2.60A + W/O BUC + 350KGF_CM2 + 11.30CW + 67.39TON

Unit: 1,000 lb.

B (ft) \ A (ft.)	10		15		20		25		30		MAX. REACH		A (ft.)
25							37.58*	37.58*			37.05*	37.05*	25.05
20					46.71*	46.71*	41.31*	39.5			36.16*	33.2	27.74
15					52.16*	52.16*	43.59*	38.27			36.64*	29.76	29.34
10					57.50*	51.12	46.15*	36.9	38.74*	28.17	38.36*	28.14	30.02
5					60.56*	49.2	47.80*	35.78			39.66*	27.9	29.84
0 (GROUND)					60.33*	48.27	47.50*	35.15			39.77*	29.07	28.78
-5			72.13*	72.13*	56.41*	48.21	43.91*	35.16			39.38*	32.22	26.75
-10	71.64*	71.64*	60.20*	60.20*	47.37*	47.37*					37.46*	37.46*	23.48
-15											33.38*	33.38*	17.38

Metric

Unit: 1,000 kg

B (m) \ A (m)	3		4.5		6		7.5		9		MAX. REACH		A (m)
7.5							18.55*	18.55*			16.75*	16.75*	7.71
6					21.55*	21.55*	18.93*	18.35			16.40*	14.92	8.50
4.5					24.13*	24.13*	20.06*	17.76			16.64*	13.45	8.96
3					26.59*	23.7	21.28*	17.11	18.16*	13.08	17.43*	12.75	9.15
1.5					27.96*	22.83	22.05*	16.59	18.21*	12.84	17.99*	12.66	9.09
0 (GROUND)					27.82*	22.41	21.93*	16.3			18.04*	13.18	8.77
-1.5			33.15*	33.15*	26.03*	22.39	20.38*	16.29			17.87*	14.58	8.16
-3	32.89*	32.89*	27.80*	27.80*	22.03*	22.03*					17.04*	17.04*	7.19
-4.5			18.48*	18.48*							14.04*	14.04*	5.68

- LOAD POINT IS THE END OF THE ARM
- CAPACITIES MARKED WITH AN ASTERISK (*) ARE LIMITED BY HYDRAULIC CAPACITIES
- LIFT CAPACITIES SHOWN DO NOT EXCEED 75% OF MINIMUM TIPPING LOADS OR 87% OF HYDRAULIC CAPACITIES
- THE LEAST STABLE POSITION IS OVER THE SIDE
- THE TOTAL MASS OF MACHINE IS 67,300 kg INCLUDED IN THIS MASS BOOM 6.65 m, ARM 2.60 m, 11,300 kg COUNTERWEIGHT, BUCKET WEIGHT 0 kg, ALL OPERATING FLUIDS AND A 75 kg OPERATOR
- LIFT CAPACITIES ARE IN COMPLIANCE WITH ISO 10567

- Rating Over Front
- Rating Over Side or 360°

DX700LC

Boom: 21'10" (6,650 mm)
Arm: 9'6" (2,900 mm)
Bucket: None
Shoe: 35.4" (900 mm)
Counterweight: 12.5 ton (11.3 metric ton)

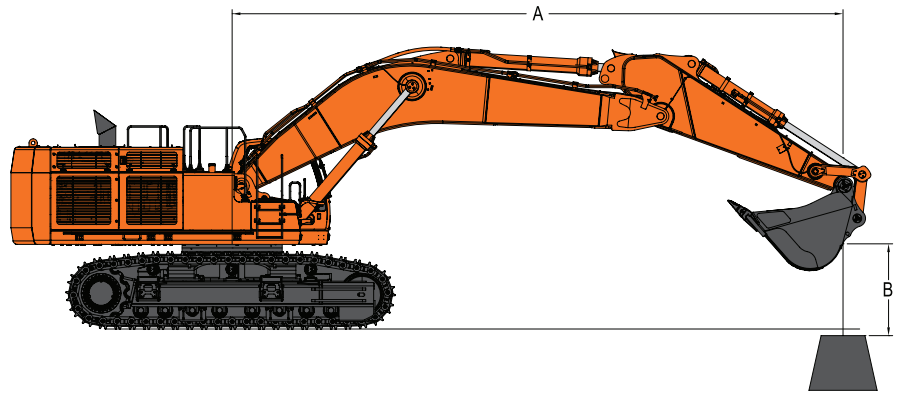

Feet - 6.6B+2.9A+WO BUC+900MM SHOE

Unit: 1,000 lb.

B (ft.) \ A (ft.)	10		15		20		25		30		MAX. REACH		A (ft.)
25							39.11*	39.11*			32.69*	32.69*	26.06
20					45.04*	45.04*	40.01*	39.72			32.00*	31.62	28.65
15					50.64*	50.64*	42.52*	38.41	35.44*	28.8	32.45*	28.47	30.21
10					56.32*	51.37	45.33*	36.97	38.89*	28.16	33.95*	26.96	30.86
5					59.95*	49.27	47.33*	35.75	39.30*	27.57	36.74*	26.7	30.69
0 (GROUND)					60.40*	48.15	47.51*	35.01			38.55*	27.71	29.66
-5			74.18*	74.18*	57.27*	47.93	44.78*	34.87			38.43*	30.47	27.70
-10	78.38*	78.38*	63.24*	63.24*	49.45*	48.53					37.15*	36.47	24.56
-15			44.18*	44.18*							32.06*	32.06*	19.68

Metric

Unit: 1,000 kg

B (m) \ A (m)	3		4.5		6		7.5		9		MAX. REACH		A (m)
7.5							17.77*	17.77*			14.78*	14.78*	8.02
6							18.34*	18.34*			14.51*	14.22	8.77
4.5					23.43*	23.43*	19.57*	17.82	17.41*	13.4	14.74*	12.87	9.22
3					26.05*	23.82	20.90*	17.14	17.88*	13.08	15.43*	12.22	9.41
1.5					27.69*	22.86	21.83*	16.58	18.13*	12.79	16.69*	12.11	9.35
0 (GROUND)					27.86*	22.36	21.93*	16.24	17.62*	12.64	17.49*	12.57	9.04
-1.5			34.13*	34.13*	26.43*	22.26	20.75*	16.16			17.44*	13.79	8.45
-3	36.04*	36.04*	29.20*	29.20*	22.96*	22.53	17.01*	16.48			16.88*	16.42	7.52
-4.5			20.81*	20.81*	15.21*	15.21*					14.72*	14.72*	6.08

- LOAD POINT IS THE END OF THE ARM
- CAPACITIES MARKED WITH AN ASTERISK (*) ARE LIMITED BY HYDRAULIC CAPACITIES
- LIFT CAPACITIES SHOWN DO NOT EXCEED 75% OF MINIMUM TIPPING LOADS OR 87% OF HYDRAULIC CAPACITIES
- THE LEAST STABLE POSITION IS OVER THE SIDE
- THE TOTAL MASS OF MACHINE IS 67,500 KG INCLUDED IN THIS MASS. BOOM 6.65 M, ARM 2.90 M, 11,300 KG COUNTERWEIGHT, BUCKET WEIGHT 0 KG, ALL OPERATING FLUIDS AND A 75 KG OPERATOR
- LIFT CAPACITIES ARE IN COMPLIANCE WITH ISO 10567

- Rating Over Front
- Rating Over Side or 360°



LIFTING CAPACITY

Boom: 25'3" (7,700 mm)

Arm: 9'6" (2,900 mm)

Bucket: None

Shoe: 35.4" (900 mm)

Counterweight: 12.5 ton (11.3 metric ton)

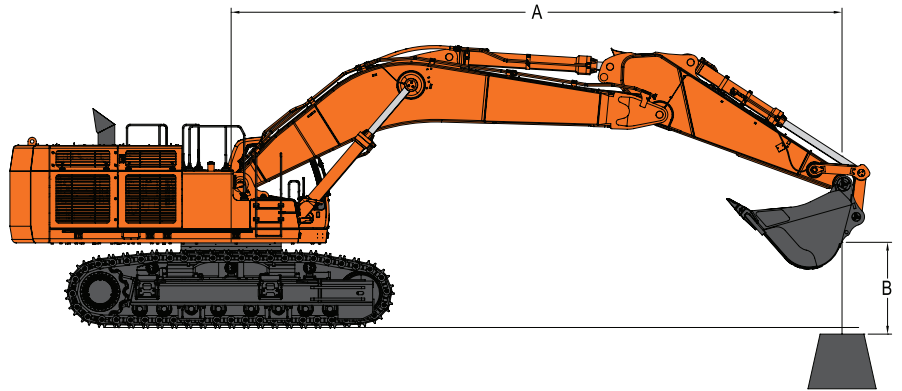

Feet -T70 + 7.70B + 2.90A + W/O BUC + 350KGF_CM2 + 11.30CW + 67.92TON

Unit: 1,000 lb.

B (ft.) \ A (ft.)	10		15		20		25		30		MAX. REACH		A (ft.)
30 ft							35.20*	35.20*			35.05*	35.05*	27.08
25 ft							35.70*	35.70*	33.56*	29.32	33.55*	28.55	30.43
20 ft					44.94*	44.94*	37.94*	37.94*	33.96*	28.88	32.83*	24.94	32.68
15 ft					51.00*	51.00*	40.96*	36.85	35.30*	28.01	32.51*	22.89	34.04
10 ft							43.81*	35.17	36.73*	27.08	31.64	21.86	34.62
5 ft					58.36*	46.36	45.59*	33.91	37.63*	26.32	31.49	21.67	34.46
0 ft					57.66*	45.67	45.73*	33.21	37.42*	25.87	32.30*	22.32	33.56
-5 ft			65.16*	65.16*	54.48*	45.69	43.84*	33.06	35.32*	25.86	31.92*	24.04	31.84
-10 ft	63.40*	63.40*	58.59*	58.59*	48.61*	46.29	39.17*	33.49			30.77*	27.48	29.16
-15 ft			46.09*	46.09*	38.53*	38.53*	28.36*	28.36*			27.68*	27.68*	25.19

Metric

Unit: 1,000 kg

B (m) \ A (m)	3		4.5		6		7.5		9		10.5		MAX. REACH		A (m)
9 m							15.99*	15.99*					15.81*	15.56	8.36
7.5 m							16.38*	16.38*	15.25*	13.69			15.19*	12.79	9.34
6 m					20.83*	20.83*	17.49*	17.49*	15.57*	13.42			14.88*	11.24	9.99
4.5 m					23.67*	23.67*	18.92*	17.07	16.24*	13			14.74*	10.35	10.39
3 m							20.24*	16.29	16.92*	12.56	14.46	9.99	14.34	9.91	10.55
1.5 m							21.05*	15.72	17.36*	12.2	14.29	9.83	14.29	9.83	10.50
0 m					26.56*	21.21	21.10*	15.4	17.29*	11.99			14.65*	10.12	10.23
-1.5 m					25.09*	21.23	20.24*	15.33	16.40*	11.97			14.48*	10.88	9.72
-3 m	28.80*	28.80*	26.91*	26.91*	22.44*	21.5	18.18*	15.52					13.98*	12.4	8.92
-4.5 m			21.38*	21.38*	18.00*	18.00*	13.72*	13.72*					12.66*	12.66*	7.75

- LOAD POINT IS THE END OF THE ARM
- CAPACITIES MARKED WITH AN ASTERISK (*) ARE LIMITED BY HYDRAULIC CAPACITIES
- LIFT CAPACITIES SHOWN DO NOT EXCEED 75% OF MINIMUM TIPPING LOADS OR 87% OF HYDRAULIC CAPACITIES
- THE LEAST STABLE POSITION IS OVER THE SIDE
- THE TOTAL MASS OF MACHINE IS 67,900 KG INCLUDED IN THIS MASS BOOM 7.70 M, ARM 2.90 M, 11,300 KG COUNTERWEIGHT, BUCKET WEIGHT 0 KG, ALL OPERATING FLUIDS AND A 75 KG OPERATOR
- LIFT CAPACITIES ARE IN COMPLIANCE WITH ISO 10567

- Rating Over Front
- Rating Over Side or 360°

DX700LC

Boom: 25'3" (7,700 mm)
Arm: 11'8" (3,550 mm)
Bucket: None
Shoe: 35.4" (900 mm)
Counterweight: 12.5 ton (11.3 metric ton)

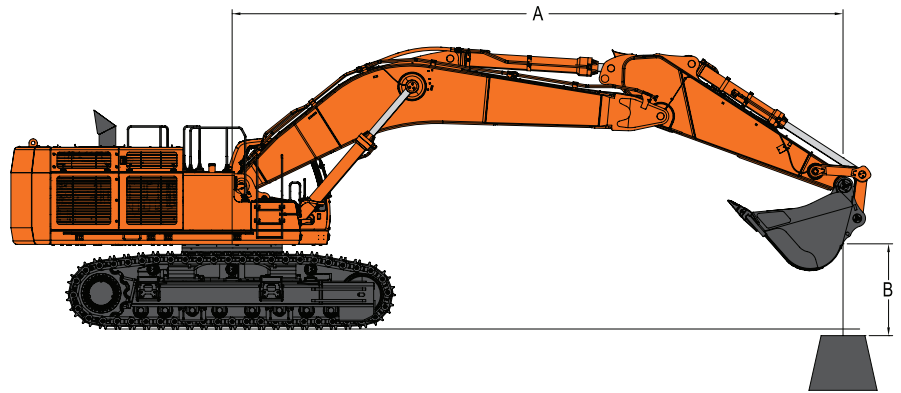

Feet -T70 + 7.70B + 3.55A + W/O BUC + 350KGF_CM2 + 11.30CW + 67.98TON

Unit: 1,000 lb.

A (ft.) \ B (ft.)	10		15		20		25		30		35		MAX. REACH		A (ft.)
30 ft													26.61*	26.61*	29.32
25 ft									31.28*	30.02			25.55*	25.55*	32.43
20 ft							35.94*	35.94*	32.29*	29.38			25.28*	23.04	34.55
15 ft					48.30*	48.30*	39.26*	37.58	33.99*	28.42	30.72*	22.17	25.64*	21.28	35.84
10 ft					54.16*	49.36	42.55*	35.78	35.79*	27.4	31.31	21.67	26.61*	20.36	36.40
5 ft					57.70*	47.08	44.94*	34.33	37.15*	26.51	30.81	21.21	28.29*	20.14	36.25
0 ft					58.34*	45.94	45.84*	33.4	37.56*	25.91	30.53	20.94	30.06	20.63	35.39
-5 ft			67.61*	67.61*	56.36*	45.64	44.86*	33.03	36.46*	25.68			30.68*	22	33.77
-10 ft	65.11*	65.11*	64.67*	64.67*	51.74*	45.98	41.50*	33.19	32.74*	25.95			30.20*	24.68	31.25
-15 ft	63.87*	63.87*	53.59*	53.59*	43.61*	43.61*	34.27*	34					28.57*	28.57*	27.61
-20 ft					28.72*	28.72*							23.62*	23.62*	22.26

Metric

Unit: 1,000 kg

A (m) \ B (m)	3		4.5		6		7.5		9		10.5		MAX. REACH		A (m)
9 m									12.43*	12.43*			12.01*	12.01*	9.04
7.5 m									14.28*	13.98			11.57*	11.57*	9.95
6 m							16.56*	16.56*	14.82*	13.65	12.36*	10.51	11.47*	10.39	10.56
4.5 m					22.41*	22.41*	18.13*	17.42	15.64*	13.19	14.08*	10.32	11.64*	9.62	10.94
3 m					25.10*	22.87	19.66*	16.58	16.49*	12.71	14.44*	10.07	12.09*	9.23	11.10
1.5 m					26.67*	21.84	20.75*	15.91	17.13*	12.3	14.31	9.84	12.85*	9.14	11.05
0 m					26.91*	21.33	21.16*	15.49	17.34*	12.02	14.16	9.7	13.64	9.36	10.79
-1.5 m			29.60*	29.60*	25.98*	21.21	20.71*	15.32	16.88*	11.9			13.92*	9.96	10.30
-3 m	28.89*	28.89*	29.77*	29.77*	23.89*	21.36	19.22*	15.39	15.32*	12			13.71*	11.15	9.55
-4.5 m	29.51*	29.51*	24.82*	24.82*	20.28*	20.28*	16.10*	15.73					13.01*	13.01*	8.47
-6 m			17.17*	17.17*	13.88*	13.88*							10.94*	10.94*	6.90

- LOAD POINT IS THE END OF THE ARM
- CAPACITIES MARKED WITH AN ASTERISK (*) ARE LIMITED BY HYDRAULIC CAPACITIES
- LIFT CAPACITIES SHOWN DO NOT EXCEED 75% OF MINIMUM TIPPING LOADS OR 87% OF HYDRAULIC CAPACITIES
- THE LEAST STABLE POSITION IS OVER THE SIDE
- THE TOTAL MASS OF MACHINE IS 67,900 KG INCLUDED IN THIS MASS BOOM 7.70 M, ARM 3.55 M, 11,300 KG COUNTERWEIGHT, BUCKET WEIGHT 0 KG, ALL OPERATING FLUIDS AND A 75 KG OPERATOR
- LIFT CAPACITIES ARE IN COMPLIANCE WITH ISO 10567

- Rating Over Front
- Rating Over Side or 360°



Boom: 25'3" (7,700 mm)
Arm: 13'9" (4,200 mm)
Bucket: None
Shoe: 35.4" (900 mm)
Counterweight: 12.5 ton (11.3 metric ton)

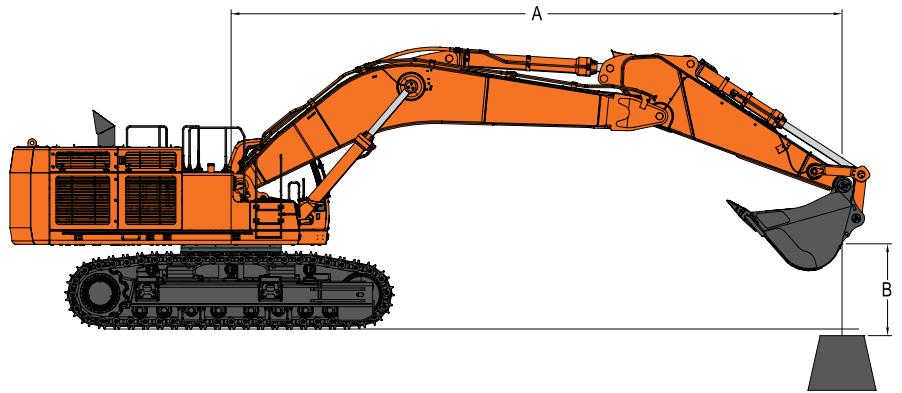

Feet -T70 + 7.70B + 4.20A + W/O BUC + 350KGF_CM2 + 11.30CW + 68.26TON

Unit: 1,000 lb.

A (ft.) \ B (ft.)	10		15		20		25		30		35		MAX. REACH		A (ft.)
30 ft									28.82*	28.82*			21.69*	21.69*	31.85
25 ft									28.97*	28.97*			20.86*	20.86*	34.73
20 ft									30.28*	29.67	28.34*	22.78	20.63*	20.63*	36.71
15 ft					44.87*	44.87*	36.96*	36.96*	32.22*	28.61	29.17*	22.26	20.87*	19.33	37.93
10 ft					51.29*	50.17	40.59*	36.08	34.30*	27.47	30.20*	21.62	21.55*	18.53	38.45
5 ft					55.88*	47.41	43.52*	34.4	36.04*	26.44	30.65	21.03	22.77*	18.31	38.31
0 ft					57.77*	45.8	45.10*	33.23	36.98*	25.67	30.19	20.6	24.66*	18.68	37.50
-5 ft			64.88*	64.88*	57.00*	45.14	44.96*	32.63	36.64*	25.26	30.00*	20.45	27.56*	19.74	35.98
-10 ft	58.49*	58.49*	68.95*	68.95*	53.63*	45.19	42.71*	32.56	34.37*	25.27			28.37*	21.81	33.63
-15 ft	75.96*	75.96*	59.40*	59.40*	47.16*	45.89	37.47*	33.06	28.11*	25.95			27.44*	25.68	30.27
-20 ft			44.75*	44.75*	35.79*	35.79*	25.95*	25.95*					24.57*	24.57*	25.49

Metric

Unit: 1,000 kg

A (m) \ B (m)	3		4.5		6		7.5		9		10.5		MAX. REACH		A (m)
9 m									13.06*	13.06*			9.79*	9.79*	9.80
7.5 m									13.24*	13.24*	10.74*	10.74*	9.45*	9.45*	10.64
6 m									13.90*	13.79	12.95*	10.62	9.36*	9.36*	11.22
4.5 m					20.81*	20.81*	17.07*	17.07*	14.83*	13.28	13.38*	10.35	9.47*	8.75	11.57
3 m					23.77*	23.25	18.75*	16.73	15.81*	12.75	13.89*	10.05	9.79*	8.4	11.72
1.5 m					25.84*	21.99	20.10*	15.95	16.62*	12.27	14.24	9.76	10.34*	8.31	11.67
0 m					26.67*	21.26	20.82*	15.42	17.06*	11.91	14.01	9.56	11.18*	8.47	11.43
-1.5 m			28.46*	28.46*	26.29*	20.97	20.76*	15.14	16.94*	11.72	13.93	9.47	12.48*	8.95	10.97
-3 m	25.99*	25.99*	31.78*	31.78*	24.77*	21	19.76*	15.1	15.97*	11.71			12.88*	9.86	10.28
-4.5 m	35.12*	35.12*	27.50*	27.50*	21.88*	21.31	17.47*	15.32	13.42*	11.97			12.48*	11.54	9.28
-6 m			21.02*	21.02*	16.92*	16.92*	12.68*	12.68*					11.28*	11.28*	7.88

1. LOAD POINT IS THE END OF THE ARM
2. CAPACITIES MARKED WITH AN ASTERISK (*) ARE LIMITED BY HYDRAULIC CAPACITIES
3. LIFT CAPACITIES SHOWN DO NOT EXCEED 75% OF MINIMUM TIPPING LOADS OR 87% OF HYDRAULIC CAPACITIES
4. THE LEAST STABLE POSITION IS OVER THE SIDE
5. THE TOTAL MASS OF MACHINE IS 68,200 KG INCLUDED IN THIS MASS BOOM 7.70 M, ARM 4.20 M, 11,300 KG COUNTERWEIGHT, BUCKET WEIGHT 0 KG, ALL OPERATING FLUIDS AND A 75 KG OPERATOR
6. LIFT CAPACITIES ARE IN COMPLIANCE WITH ISO 10567

- Rating Over Front
- Rating Over Side or 360°

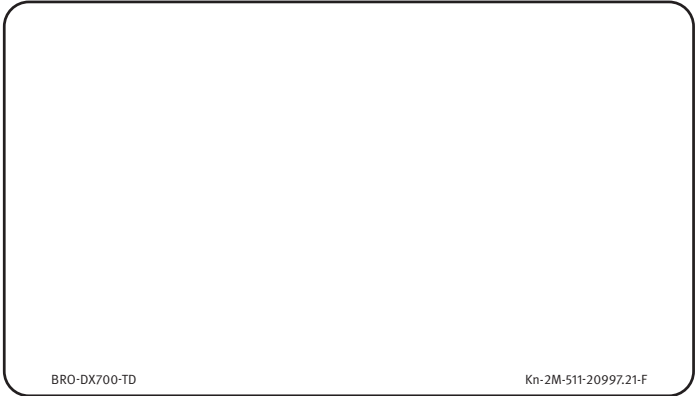

BRO-DX700-TD

Kn-2M-511-20997,21-F

For more information visit www.doosanequipment.com



Doosan® is a registered trademark of Doosan Corp. in the United States.
© 2011 Doosan Infracore Construction Equipment America – All rights reserved.